



AURORA[®]

Wind Inverters

INSTALLATION AND OPERATION MANUAL

REVISION TABLE

Document Revision	Author	Date	Change Description
Rev 1.0	Federico Mastronardi	Dec. 5, 2008	First emission



SAVE THESE INSTRUCTIONS!



IMPORTANT SAFETY INSTRUCTIONS

POWER-ONE: Reproduction and disclosure, even partially, of the contents of this manual are strictly forbidden without prior authorization of Power-One.

IMPORTANT SAFETY INSTRUCTIONS

This manual contains important safety and operational instructions that must be accurately understood and followed during the installation and maintenance of the equipment.

To reduce the risk of electrical shock hazards, and to make sure the equipment is safely installed, special safety symbols are used in this manual to highlight potential safety hazard and important safety information. The symbols are:



WARNING: the paragraphs highlighted by this symbol contain processes and instructions that must be absolutely understood and followed to avoid potential danger to people.



NOTE: the paragraphs highlighted by this symbol contain processes and instructions that must be rigorously understood and followed to avoid potential damage to the equipment and negative results.

The equipment is provided with several labels, some of them with a yellow background, which are related to safety issues.

Make sure to read the labels and fully understand them before installing the equipment.

The labels utilize the following symbols:

	Equipment grounding conductor (Main protective grounding, PE)
	Alternate Current (AC) value
	Direct Current (DC) value
	Phase
	Grounding (Earth)

USEFUL INFORMATION AND SAFETY STANDARD

INTRODUCTION

- The installation of AURORA must be performed in full compliance with national and local standards and regulations.
- AURORA has no spare parts to replace.
For any maintenance or repair, please, contact the nearest authorized repair centre. Please contact your reseller if you need to know the nearest authorized repair facility.
- Read and understand all the instructions contained in this manual and become familiar with the safety symbols in the relevant paragraphs before you install the equipment
- The connection to the distribution grid must be done only after receiving approval from the distribution utility as required by national and state interconnection regulations, and can be done only by qualified personnel.
- The wind turbine need to be blocked with a mechanical brake prior to be connected to AURORA to make sure that there is no voltage on the cable that can result in a dangerous safety hazard.

GENERAL

During inverter operation, some parts can be powered, some not insulated and, in some cases, some parts can move or rotate, or some surfaces be hot.

Unauthorized removal of the necessary protections, improper use, wrong installation or wrong operation may lead to serious damage to people and objects.

Transport, handling, installation, commissioning and maintenance must be performed by qualified and trained personnel (all relevant accident prevention rules must be strictly observed)

According to these basic safety rules, qualified and trained people must possess skills required for assembly, start-up and operation of the product, and have necessary qualifications to perform such operations.

ASSEMBLY

Devices shall be assembled and cooled according to the specifications mentioned in the corresponding documents.

In particular, during transportation and handling, parts shall not be bent and/or the insulation distances shall not be changed. There should be no contact between electronic parts and connection terminals.

Electrical parts must not be mechanically damaged or destroyed (potential health risk).

ELECTRICAL CONNECTION

With the inverter powered, comply with all national regulations on accidents prevention.

Electrical connections shall be carried out in accordance with the applicable regulations, such as conductor sections, fuses, PE connection, etc.

OPERATION

Systems with inverters shall be provided with further control and protective devices in compliance with the corresponding safety rules, such as those relating to the compliance with technical equipment, accident-preventing regulations, etc. Any calibration change shall be made using the operational software. Once the inverter has been disconnected from the power grid, powered parts and electrical connections shall not be touched as some capacitors could be charged. Comply with all corresponding marks and symbols present on each device. During operation, make sure that all covers and doors are closed.

MAINTENANCE AND SERVICE

Comply with manufacturer's recommendations.

SAVE ALL DOCUMENTS IN A SAFE PLACE!

PVI-6000-OUTD-UK-W

This document applies to the above-mentioned inverters, only.



Fig.1 - Name plate

The name plate affixed to the inverter provides the following information:

- 1) Manufacturing Part Number
- 2) Model Number
- 3) Serial Number
- 4) Week/Year of Manufacture

CONTENTS

1	INTRODUCTION	10
2	SYSTEM DESCRIPTION	11
2.1	KEY ELEMENTS OF A WIND ENERGY SYSTEM: “WIND TURBINE” AND “GENERATOR”	11
2.2	DATA MONITORING AND TRANSMISSION	14
2.3	TECHNICAL DESCRIPTION	14
2.4	SAFETY FEATURES	15
2.4.1	<i>Anti-Islanding</i>	15
2.4.2	<i>Wind generator Ground Fault</i>	15
2.4.3	<i>Additional safety features</i>	15
3	INSTALLATION.....	17
3.1	PACKAGE INSPECTION.....	17
3.2	INSPECTING PACKAGE CONTENTS.....	18
3.3	SELECTING THE PLACE OF INSTALLATION	19
3.4	WALL MOUNTING.....	20
3.5	BEFORE PERFORMING ELECTRICAL CONNECTIONS	23
3.6	ELECTRICAL CONNECTIONS	26
3.7	STEP 6/6 (OPTIONAL): CONNECTION OF THE FREQUENCY SIGNAL FROM THE WIND TURBINE.	28
3.8	HOW TO ACCESS THE INTERNAL TERMINAL BOARDS THROUGH THE FRONT PANEL	28
3.9	REPLACING THE CR2032 LITHIUM BATTERY.....	29
3.10	REPLACING THE MEMORY	30
4	START UP.....	31
5	MONITORING AND DATA TRANSMISSION.....	32
5.1	USER’S INTERFACE MODE	32
5.2	AVAILABLE DATA.....	34
5.2.1	<i>Real-time operational data</i>	34
5.2.2	<i>Internally logged data</i>	35
5.3	LED INDICATORS	35
5.4	MESSAGES AND ERROR CODES	39
5.5	DISPLAY LCD	42
5.5.1	<i>Connection of system to the grid</i>	42

5.5.2	<i>Error messages</i>	43
5.5.3	<i>First phase - electric parameter monitoring</i>	44
5.5.4	<i>Main menu</i>	47
5.5.5	<i>Statistics</i>	47
5.5.5.1	Lifetime	48
5.5.5.2	Partial.....	48
5.5.5.3	Today.....	49
5.5.5.4	Last 7 days.....	49
5.5.5.5	Last Month.....	49
5.5.5.6	Last 30 Days.....	50
5.5.5.7	Last 365 Days.....	50
5.5.5.8	User period	50
5.5.6	<i>Settings</i>	51
5.5.6.1	Address	52
5.5.6.2	Display set.....	52
5.5.6.3	Service.....	53
5.5.6.4	New password.....	53
5.5.6.5	Cash.....	53
5.5.6.6	Time	54
5.5.6.7	Language.....	54
5.5.6.8	START UP voltage.....	54
5.5.6.9	Autotest.....	54
5.5.6.10	Alarm	55
5.5.6.11	Remote control.....	56
5.5.6.12	UV Prot.time	57
5.5.6.13	Alarm Message	57
5.5.7	<i>Info</i>	59
6	DATA MONITORING AND COMMUNICATION.....	61
6.1	CONNECTION THROUGH RS-485 SERIAL PORT OR RJ12 CONNECTOR.....	61
6.1.1	<i>RS-485 serial port</i>	61
6.1.2	<i>RJ12 connectors</i>	62
6.1.3	<i>Daisy chain</i>	63
6.2	SERIAL CONNECTION WITH USB PORT.....	65
6.3	MEASUREMENT ACCURACY	66
7	TROUBLESHOOTING.....	67

8	TECHNICAL FEATURES.....	69
8.1	INPUT VALUES	69
8.2	OUTPUT VALUE	70
8.3	GRID PROTECTION CHARACTERISTICS	70
8.4	GENERAL CHARACTERISTICS	71
8.5	POWER DERATING	72

1 INTRODUCTION

This document contains technical description of AURORA Wind inverters. It is intended to provide the installers and users with all the necessary information about installation, operation, and use of AURORA Wind inverters.

2 SYSTEM DESCRIPTION

The AURORA inverter is capable of feeding power to the grid converting the power generated by a wind turbine. The wind turbine (using a generator) converts the mechanical energy from wind into the 3-phase AC voltage. The voltage and frequency of the AC generated by the wind turbine are variable and depend on the wind speed. To be exported to the utility grid the power need to be converted to the frequency and voltage level of the grid.

When used in parallel with the grid, the alternate current generated by the inverter is directly fed into the distribution circuit, which is also connected to the public power distribution grid.

The wind energy system can thus powers all the connected users, such as lighting devices, household appliances, etc.

When the wind turbine is not generating enough energy, the power required by the connected users is provided by the public power grid. If the energy produced by the wind turbine exceeds the quantity required by the user's loads, then extra power is directly fed to the grid, becoming available to other users.

According to national and local standards and regulations the energy produced can be sold to the electrical utility or credited to the user against future consumption, thus providing financial savings.

2.1 Key elements of a wind energy system: “WIND TURBINE” and “GENERATOR”

Two elements are necessary in order to harvest the wind energy: a wind turbine that will spin based on the wind speed and a generator.

The turbine forces the generator to rotate thus producing energy that can be exported to the grid.

The most common turbine design has a horizontal rotor with 2 or 3 vertical fiberglass blades forming the propeller which may have a fixed or a variable tilt.

The generator is fixed on the rotor. Usually for the small wind system a synchronous permanent magnet generator is used. The current generated by this type of generators has variable voltage and frequency depending on the turbine speed. To be exported to the grid this needs to be is converted to current.

The conversion is done in 2 steps:

- A) The 3-phase AC voltage from the generator is filtered and converted to the DC voltage. This conversion can be done inside the turbine or using an interface box between the generator and the inverter.

- B) The resulting DC output is connected to the AURORA input and converted into AC power with the appropriate voltage and frequency to be exported to the grid.

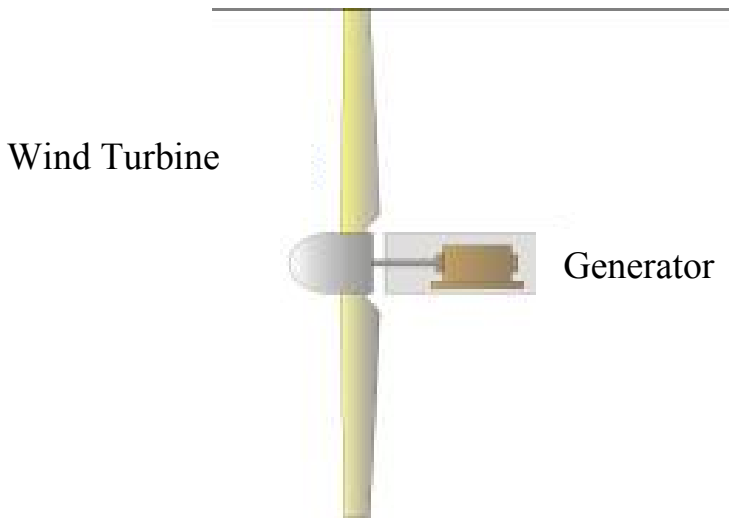

Fig. 2 - Wind Turbine – Generator



WARNING: The DC voltage input to the inverter shall not exceed 600Vdc for any reason, in order to avoid damage to the equipment.

NOTE: A minimum input voltage of 50Vdc is required for the AURORA inverter to start the grid connection sequence. Once connected, the AURORA inverter will transfer the maximum power available for any input DC voltage value in a 50V to 580Vdc range to the grid.

The max output current from the generator or an interface device shall be always within the inverter limits. In the AURORA inverter the total max input current is 36Adc.

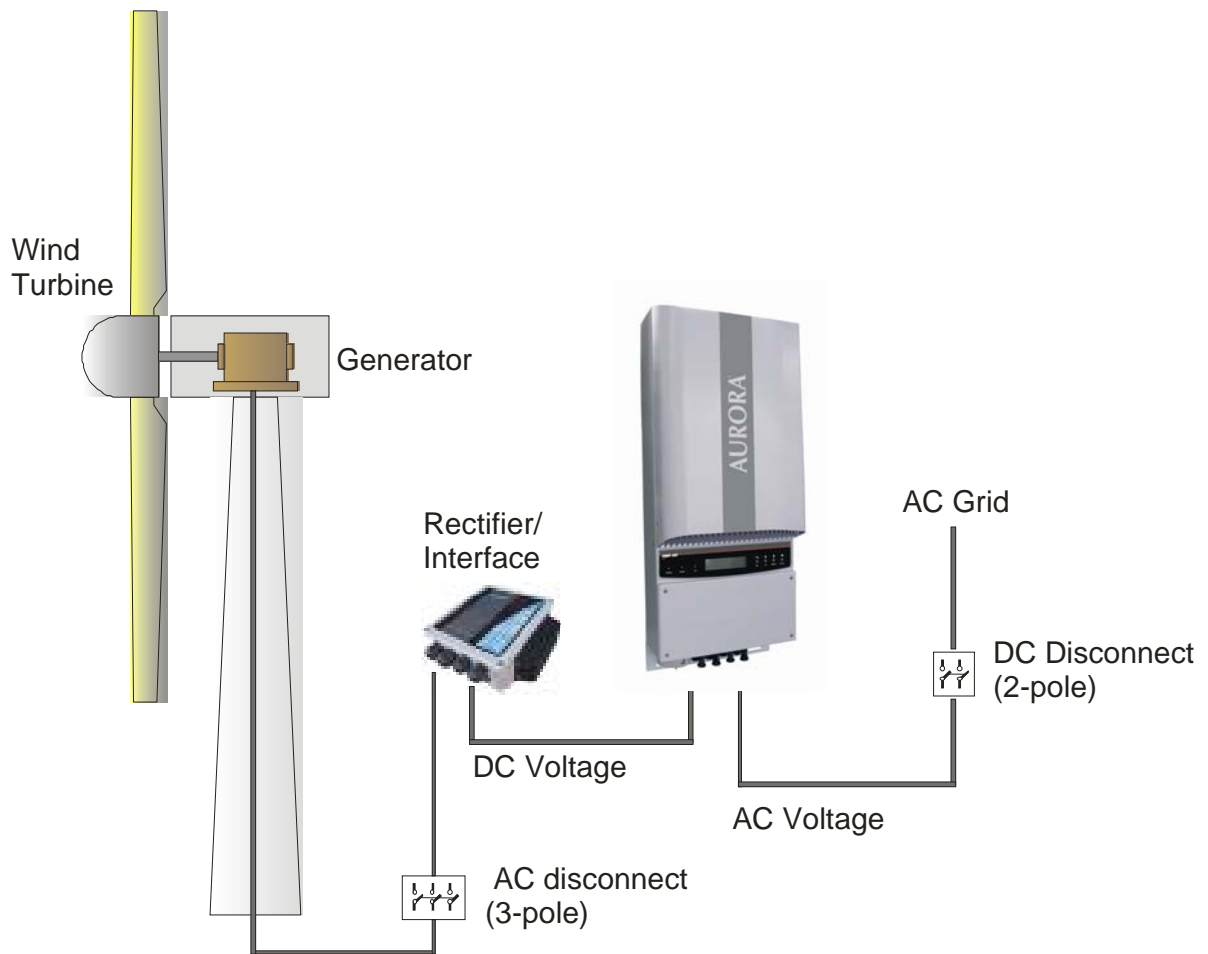

Fig. 3 - Wind energy system diagram

2.2 Data monitoring and transmission

In system with more than one inverter, remote monitoring can be implemented through a sophisticated communication system based on an RS-485 serial interface. A USB port is available in the inverter to facilitate access during installation. An optional AURORA Easy-Control system is also available for remote monitoring via the Internet, analogue modem or GSM digital modem.

2.3 Technical Description

Figure 4 shows a block diagram of the AURORA inverter. The main elements are the input DC-DC converters (further “boosters”) and the output DC-AC inverter. Both the DC-DC converters and the output inverter operate at high switching frequency to enable a compact design and relatively low weight.

For increased conversion efficiency, the version of the AURORA inverter does not have a transformer therefore no galvanic isolation is provided between the input and output. However, the AURORA inverter is equipped with the necessary safety features to ensure safe operation in compliance with all applicable regulations without an isolation transformer.

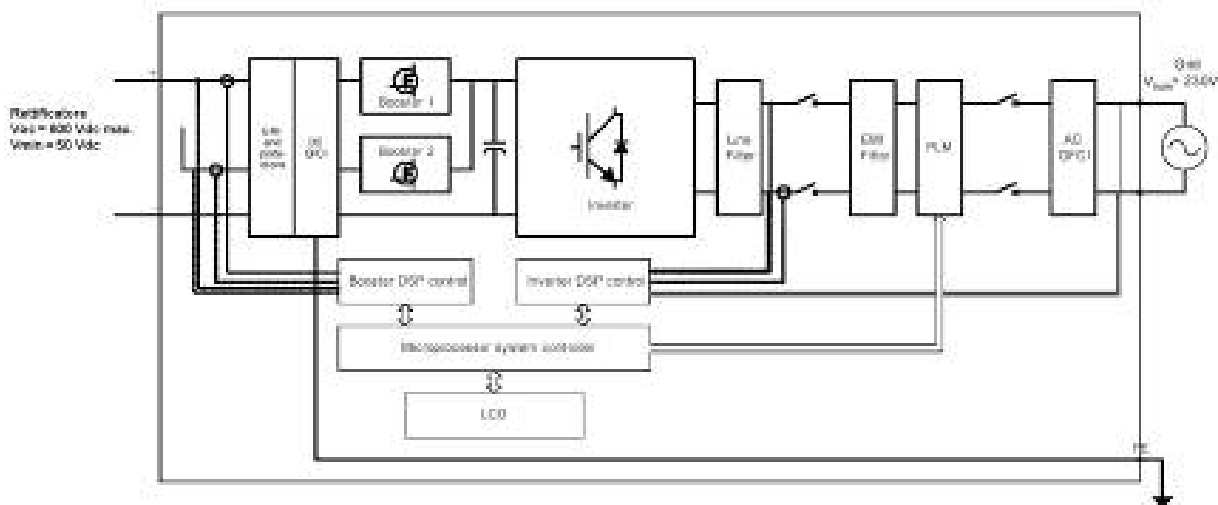

Fig.4 - AURORA inverter block-diagram

The block diagram shows an AURORA PVI-6000-OUTD with the two input DC-DC converters; in the Wind version the 2 converters are always connected in parallel.

Thanks to its high efficiency and excellent thermal design, the AURORA inverter provides maximum power operation in a broad range of ambient temperatures.

The inverter is controlled by two independent DSPs (Digital Signal Processors) and one central microprocessor.

This way, grid connection is controlled by two independent computers in full compliance with electrical power supply and safety regulations.

The AURORA operating system continuously communicates with all functional blocks and processes the data to ensure optimal performance, as well as the highest possible efficiency under all wind speed and load conditions, always in full compliance with the applicable directives, standards and regulations.

2.4 Safety Features

2.4.1 *Anti-Islanding*

When the local power distribution grid fails or when it is shut down for maintenance, the AURORA inverter shall be disconnected from the grid, to protect the people working on the grid, and in full compliance with the applicable national standards and regulations. To avoid any possible islanding operation, the AURORA inverter is equipped with the automatic disconnection protective system called Anti-Islanding. The AURORA PVI-6000-OUTD-UK-W model is equipped with a state-of-the-art anti-islanding protection system certified to the following standards and regulations:

- G83/1 standard

2.4.2 *Wind generator Ground Fault*

A sophisticated ground protection circuit continually monitors the ground connection. When a ground fault is detected, this circuit shuts down the AURORA inverter and turns on the red LED on the front panel to indicate a ground fault condition. The AURORA inverter is equipped with a terminal for the system grounding conductor; see section 3.6 for more details.



NOTE: For more details regarding the AURORA shutdown or possible causes of malfunction, please, refer to sections 5.3 and 5.4.

2.4.3 *Additional safety features*

The AURORA inverter is equipped with additional protections to guarantee safe operation under any circumstances. The protections include:

- constant monitoring of the grid voltage to ensure that voltage and frequency remain within the specified limits

-
- automatic power limit based on internal temperature monitoring to avoid overheating (heat sink temperature $\leq 70^{\circ}\text{C}$ [158°F]).

The redundancy of safety features implemented in the AURORA inverter guarantees completely safe operations under any conditions

3 INSTALLATION



WARNING: The electrical installation of AURORA must be performed in compliance with applicable local and national standards and laws.



WARNING: The connection of AURORA to the electrical distribution grid must be performed only after receiving authorization from the utility that operates the grid

3.1 Package Inspection



NOTE: The shipper delivered your AURORA inverter to the carrier safely packaged and in perfect condition. Upon acceptance of the package, the carrier assumes responsibility for its safe delivery. In spite of careful handling during transportation, damage to package or its contents sometimes occurs.

The customer is encouraged to perform the following checks:

- Inspect the shipping box for apparent damage, such as holes, cracking, or any signs of possible damage to its contents.
- Record any damage or shortage in the receiving documents and have the carrier sign his/her full name.
- Open the shipping box and inspect the contents for internal damage. While unpacking, be careful not to discard any equipment, parts or manuals. If any damage is detected, call the delivering carrier to determine the appropriate action. Save all shipping material in case the carrier should send an inspector to verify damage!
- If the inspection reveals damage to the AURORA inverter, call your supplier, or authorized distributor. They will determine if the equipment should be returned for repair. They will also provide instructions on how to get the equipment repaired.
- It is the customer's responsibility to file a claim with the carrier. Failure to file a claim with the carrier may void all warranty service rights for any damage.
- Save the original package your AURORA inverter arrived in for use in case you should need to return it for repair in the future.

3.2 Inspecting package contents

Description	Quantity
Inverter AURORA	1
Bag containing: 6.3x70 screws 3 pc. 3 SX10 wall anchors 3 pc. Torx20 wrench 1 pc M6x10 screw 1 pc d.18 washer 1 pc	1
Copy of this manual	1
Certificate of warranty	1
CD-ROM with communication software	1

3.3 Selecting the place of installation

The installation place should be selected based on the following considerations:

- Height from ground level should be enough to ensure that display and status LEDs are easy to read.
- Select a well ventilated place sheltered from direct sun radiation. Choose a place that allows unobstructed airflow around the unit.
- Allow sufficient room around the unit to enable easy installation and removal from the mounting surface.
- A door is provided on the unit's front panel for hardware maintenance purpose. The USB port for software connection is on the right side of the inverter (protected by a cover); installation should provide free access to this side, otherwise you will have to remove the unit from its mounting surface during maintenance operations.

The following figure shows the recommended minimum clearances around the inverter:

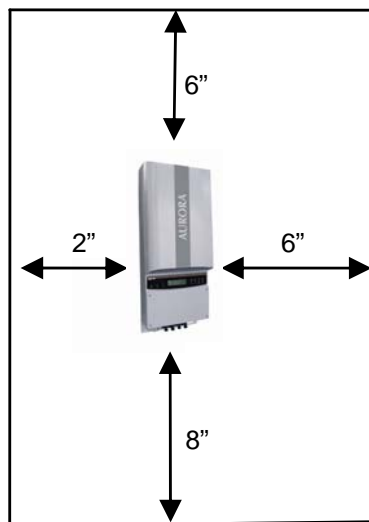

Fig.5. - Minimum clearances around AURORA inverter

3.4 Wall mounting

AURORA should be mounted in a vertical position as shown in Fig.6.

The package includes a hardware kit with three 6.3x70 steel screws and 3 SX10 wall anchors for installation of a metal bracket to a masonry wall. Screws and wall anchors can be installed using 3 of the 5 holes available on the bracket (reference part C in the pictures below).



WARNING: Bracket shall be mounted vertically on wall: spring side shall face up, while side with M6 PEM shall face down.

Since the wall can be made from different construction materials, it is the installer's responsibility to provide suitable mounting hardware. We recommend using stainless steel screws.

For concrete wall mounting the hole should be min. 8 mm in diameter and min. 70 mm deep.

Hang AURORA on the spring at the bracket top, by means of the metal mount fastened to the upper part at inverter back. The central part of this plate features a seat for fastening the spring (see Part A in Fig. 6).

Once inverter top end is secured in place, you need to secure its bottom end.

From inverter front, use an M6x10 screw and washer to secure the unit to the bracket PEM, starting with the center slot of the lower plate (Part B in Fig. 6).

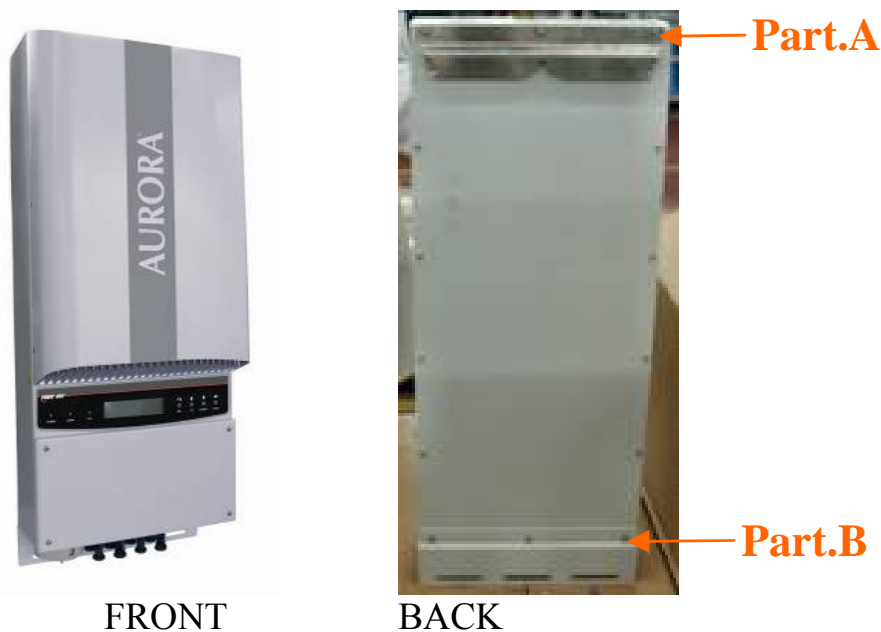

FRONT

BACK



Fig.6 -. AURORA wall mounting

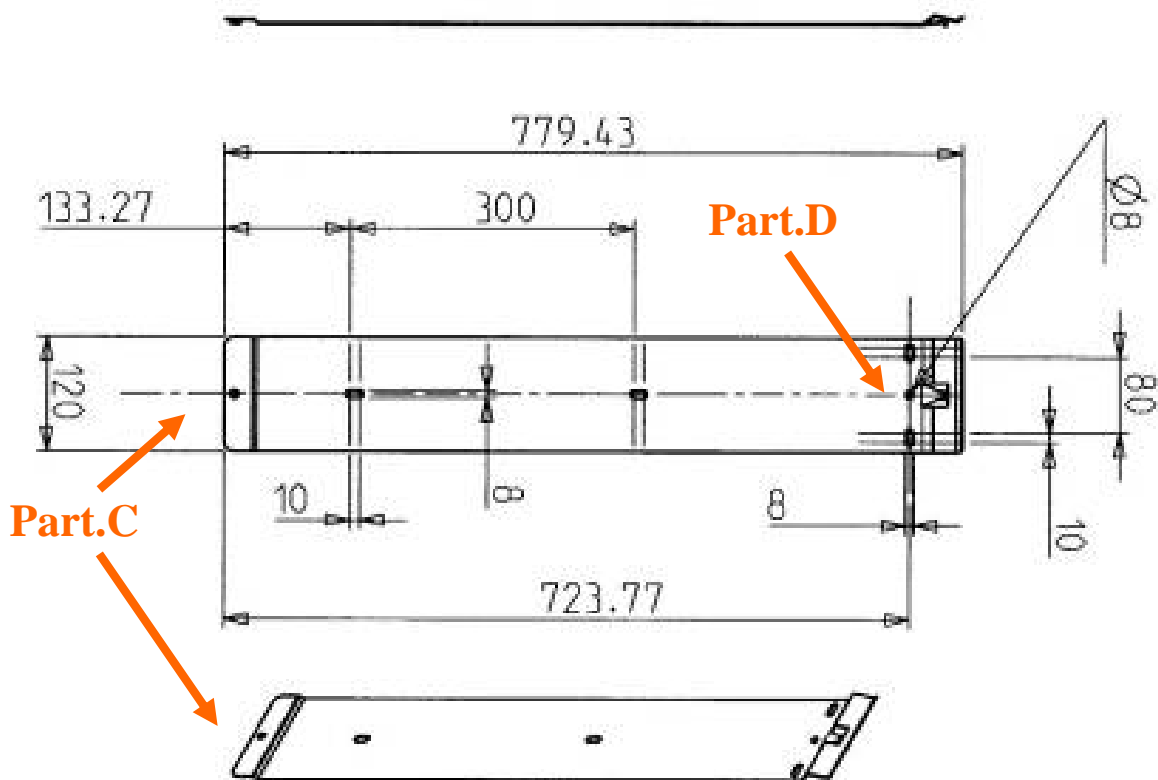

NOTE: Ensure that the AURORA inverter is not exposed to direct sun radiation or other external heat sources, including the units installed underneath it (see Fig. 7). If several inverters are stacked up, the heat generated by the inverters placed at the bottom of the stack could cause ambient temperature to rise and affect the operation of the inverters in the upper rows. Temperatures exceeding 40°C could result in the derating of the output power of the units placed in the upper rows.

A combination of high output power and high ambient temperature will result in a significant power derating and a lower energy production. For proper cooling, make sure to install AURORA to allow unobstructed air flow (for instance, the front panel should never face a solid surface).



Fig.7 - Recommended installation of AURORA inverters



NOTE: Although tilted mounting is allowed (see Fig. 8) it will cause increased power dissipation and may result in output power derating.



WARNING: Unit surface may become very hot during operation. DO NOT touch unit surface to avoid burns.

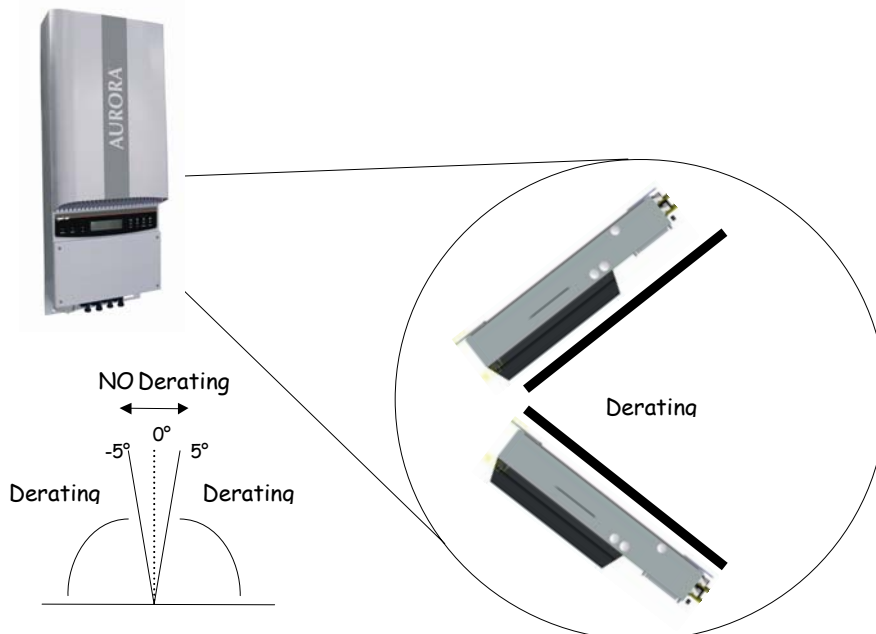

3.5 Before performing electrical connections



WARNING: Electrical connections shall be performed only after the AURORA inverter is securely mounted to the wall.



WARNING: The connection of the AURORA inverter to the electrical distribution grid must be performed by qualified operators and only after receiving authorization from the utility that operates the grid.



WARNING: For a step-by-step description of the correct procedure, please, read and follow the instructions provided in this section (and its subsections) while observing all safety warnings. Any operation that does not comply with the instructions can lead to conditions hazardous to personnel and/or equipment damage.



WARNING: Always respect the nominal ratings of voltage and current defined in Section 8 (Technical Characteristics) when designing your system. When designing the system make sure the following limits are never exceeded:

- Maximum DC voltage input: 600Vdc under any condition.
- Maximum DC current input to the 2 parallel input: 32Adc under any condition.



WARNING: Check the National and local standards and regulations to make sure your electrical installation and design are in compliance with them.



NOTE: In accordance with the typical assembly diagram (see Fig. 9) an AC disconnect switch with the overload protection (breaker) must be used to connect the AURORA inverter to the grid. Recommended ratings for the disconnect switch are 40A, 240VAC.

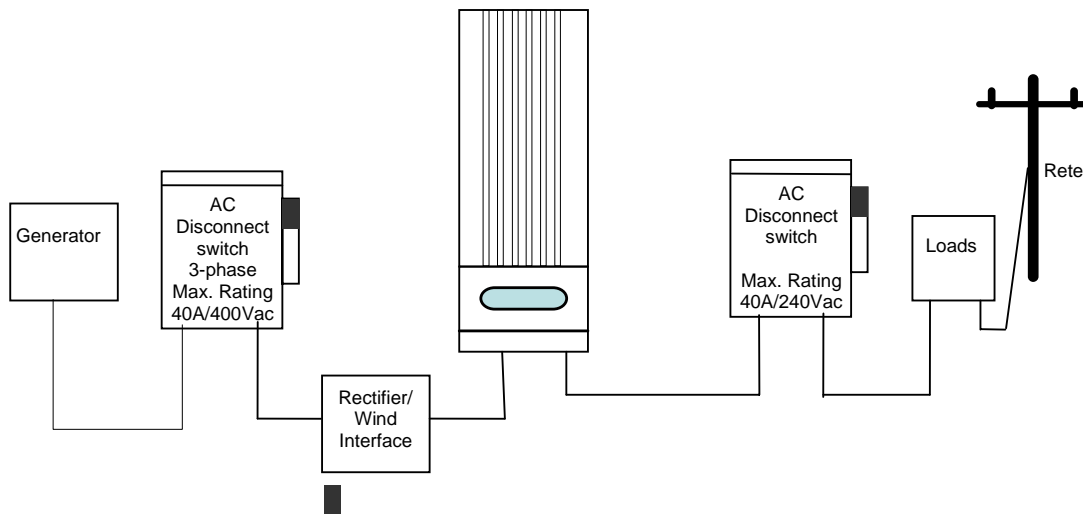

Fig.9 - Wiring diagram



WARNING: When disconnecting the AURORA inverter, always open the AC disconnect switches to disconnect the inverter from the grid and from the generator. Wait until the LEDs on the front panel turn off before unplugging the multiple contact connections from the DC input.



WARNING: When selecting the power supply cables for AURORA connections, carefully consider nominal operating voltage, insulation voltage, maximum operating temperature, current density and flammability rating. All of these values must comply with the maximum current density ratings required by applicable local rules. A key parameter to consider in cable selection is cable loss, as exceeding loss will lead to lower efficiency.

The maximum diameter allowed for the conductors to be assembled to the terminal blocks for grid connection is 0.16". The supplied M32 cable gland accepts wires up to 0.19".

The following items are located on the bottom of the inverter (see Fig. 10, from right to left):

- Two holes sealed with waterproof caps. Remove the caps to gain access to the connectors for data serial transfer via the RS485 port. One hole is for the input serial cable and the other for an output cable, if fitted (output cable is required when several inverters are connected in a daisy-chain configuration, see Section 6).
- Cable gland for AC grid connection

- Cable gland for DC connection to the rectifier.



Fig. 10 - Connectors on the bottom of the inverter and their labels



WARNING: When making the electrical connections follow the procedure exactly to avoid exposure to dangerous voltages. Each step of the procedure is explained in the following paragraphs. To disconnect the AURORA inverter, perform steps 1/6 and 2/6 and then disconnect the AC and DC connectors.

- The wind turbine need to be blocked with a mechanical brake prior to be connected to the AURORA inverter to make sure that there is no voltage on the cable that can result in a safety hazard.

3.6 Electrical Connections

Step 1/6: Open the AC grid disconnect switch

Step 2/6: Open the Wind Generator AC disconnect breaker.

Step 3/6: Unscrew the 4 screws to open the front panel

Step 4/6: Connect the inverter to the AC grid disconnect switch



WARNING: Use suitable low-impedance cables to connect the inverter to the AC disconnect switch.



WARNING: The inverter must be connected to the AC grid disconnect switch using a three-wire cable with two line wires and a neutral wire.



- 1) Route the cable from the inverter to the AC disconnect
- 2) Connect the three-pole cable to AURORA using the cable gland on the case
- 3) Connect the three wires as follows:
 - terminal 1 – to Line
 - terminal 2 – to Neutral
 - Terminal 3 – no connection
 - Screw terminal  – Protection earth 



Fig.11 - AC wire terminal block



NOTE: If you have installed a meter between the AC disconnect and the AURORA inverter, follow the procedure outlined above when connecting to the meter.

Step 5/6: Connect AURORA to the Rectifier/Wind Interface Box



WARNING: Prior to connecting the AURORA inverter to the rectifier check, using a proper meter, that the polarity and the voltage value between the positive and negative terminal are correct. The output voltage polarity from the rectifier should match the “+” and “-” symbols.

Referring to Fig.12 use the following procedure:

- 1) Verify the presence of the two wires connecting the two DC input channels in parallel (the inverter is shipped from the factory with the two wires already connected).
- 2) Connect the positive DC cable from the rectifier or Wind Interface to the positive terminal block inside the AURORA inverter (red cable on Fig 12).
- 3) Connect the negative DC cable from the rectifier or Wind Interface to the negative terminal block inside the AURORA inverter (black cable on Fig 12).



Fig.12 - DC section cables

Power-One recommends using the Wind Interface box p/n PVI-7200-Wind-Interface-US. Refer to the Aurora Wind Interface User Manual for more details.

3.7 Step 6/6 (optional): Connection of the frequency signal from the wind turbine.

If the MPPT is set using the wind turbine frequency, the frequency signals available from the rectifier (marked Wind Speed + , Wind Speed – on the AURORA Wind Interface) shall be connected to the pins marked +WT and –WT on the terminal block of the AURORA inverter shown in Fig. 12.

3.8 How to access the internal terminal boards through the front panel



WARNING: Shock hazard! Before removing the front panel, disconnect AURORA from both the AC and DC side and allow 5 minutes for the internal capacitors to discharge.

To remove the front panel, remove the 4 screws as shown in Fig. 13 using the flat-blade screwdriver.



Fig.13 - AURORA with front panel

After replacing the front panel, tighten the screws to 1.5 Nm (13.2 in-lbs) to ensure proper sealing.

3.9 Replacing the CR2032 lithium battery



WARNING: This component should only be replaced by qualified personnel.

The AURORA inverter has a CR2032 lithium battery. When the battery is nearing the end of its life, a corresponding message appears on the LCD display.

To replace the battery, remove the front panel (see Fig. 13) to get access to the battery holder shown in Fig. 14.

Note that the battery will not fit into its holder when pressed from the top down. Instead, slide the battery into its holder from the side, while holding it tilted at a 30° angle.

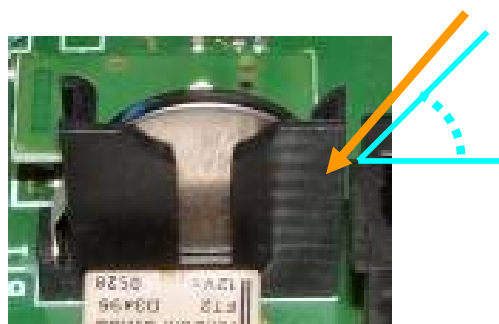

Fig. 14 - Battery in place

3.10 Replacing the memory

All energy output logs are stored in this memory. If you need to replace the inverter, the memory can be removed from the old unit and placed into the new inverter. This way, you will retain all system logs and keep saving future daily logs into the same memory (see Fig. 15)

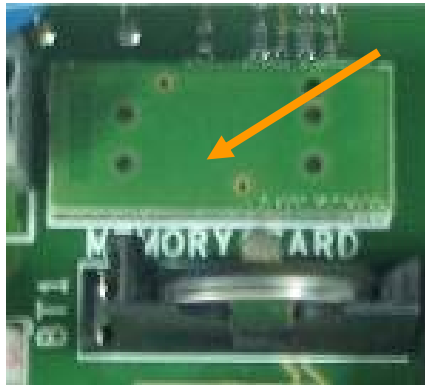

Fig. 15 - Inverter memory



WARNING: This component should only be replaced by qualified personnel.



WARNING: Make sure to insert the memory connector pins correctly into the board connector.

4 START UP



WARNING: Do not place any items on AURORA during operation.



WARNING: Do not touch the heat sink when the inverter is operating, as some parts may be hot and cause burns.

Start-up procedure:

1) Switch the AC breaker ON. If the speed of the turbine is high enough to generate at least 50V DC on the rectifier output, the AURORA inverter will turn on (the display lights on). Note that the inverter is powered directly from the wind generator; therefore if the turbine is not rotating, the inverter will turn OFF.

2) Switch the Grid DC breaker ON.

3) Once both breakers are ON, the inverter starts the grid connection sequence. The check routine may take from 30 seconds up to several minutes, depending on grid condition. The routine is indicated by the flashing green LED marked POWER.

Three screens are shown on the display during the check routine:

- Measuring isolation resistance: “Measuring Riso...” , connection in progress with progress indication.
- Grid voltage value and status compared to specified values (within/outside range).
- Grid frequency value and status compared to specified values (within/outside range).

4) When the connection sequence is completed, the AURORA inverter starts operating. Normal operation is indicated by a warning sound and the green LED staying permanently ON. This means that wind energy is sufficient to export power to the grid.

- If the check routine gave a negative result, the inverter will repeat the procedure until all grid voltage and frequency parameters and grid configuration are found to be in the specified range. During this process, the green LED will keep flashing.

5 MONITORING AND DATA TRANSMISSION

5.1 User's Interface Mode



WARNING: The RS-485 cable must provide at least 600V insulation.

The AURORA inverter operates automatically and needs no particular supervision. If the turbine speed is not enough to generate power for the grid, the inverter disconnects automatically and goes into the standby mode.

The operating cycle is resumed automatically when the turbine speed and therefore the input voltage become high enough. This is indicated by the LEDs.

The AURORA inverters can provide operational data in the following ways:

- LED indicators
- Operational data on the LCD display
- Data transmission on a dedicated serial RS-485 line. Data can be collected by a PC or a data logger equipped with an RS-485 port. If an RS-485 line is used, it may be convenient to use the AURORA RS-485/RS232 Serial Interface Converter model number PVI-RS232485. An optional AURORA Easy Control data logger is also available.
- Data transmission via a USB cable. This type of connection is typically used when monitoring a single inverter and for maintenance purposes. To connect the USB cable, remove the waterproof plug at the bottom end of the inverter's right wall (Fig.16).



Fig.16 - USB port location

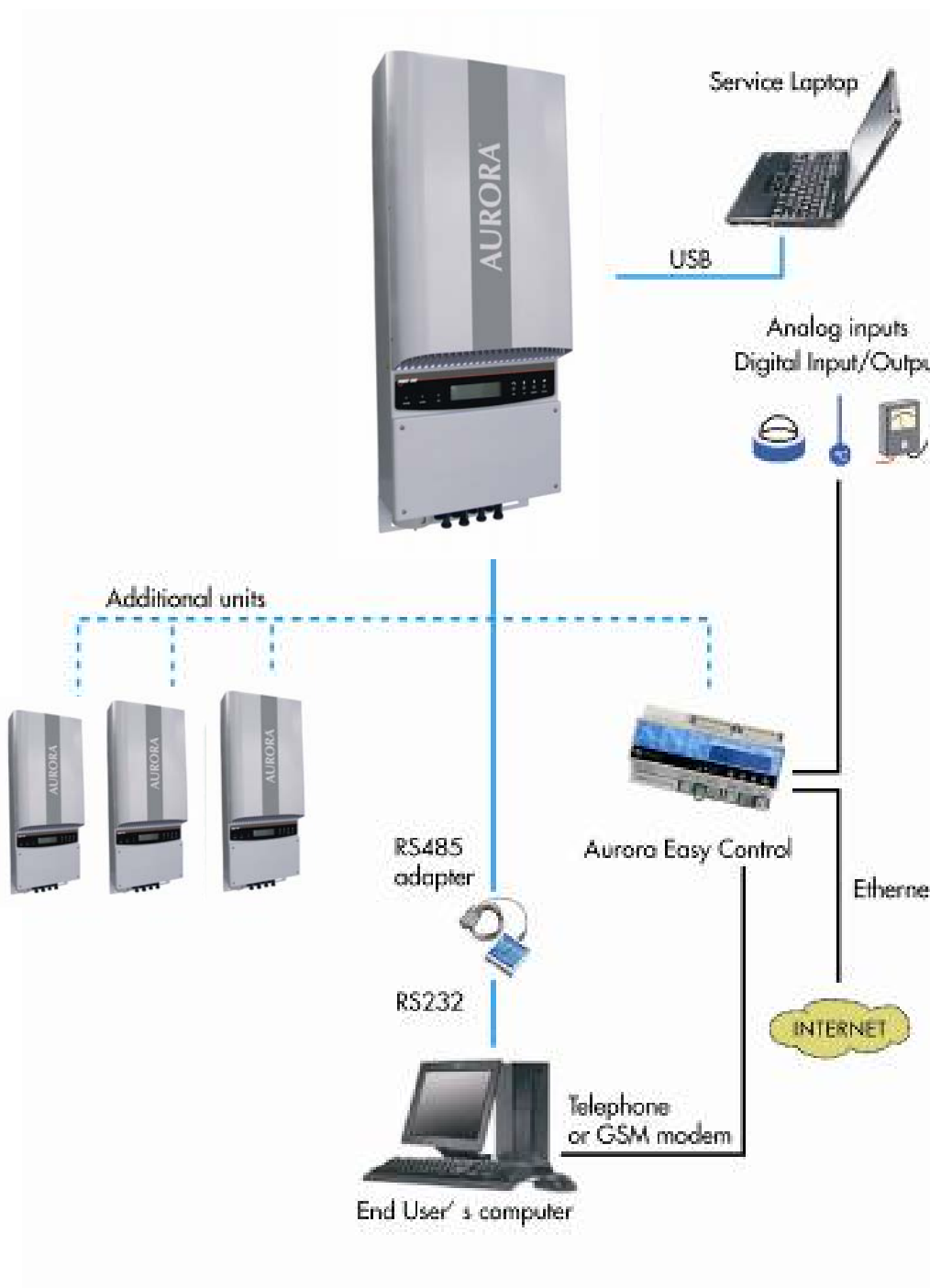

Fig. 17 - Data Transmission Options

5.2 Available Data

AURORA provides two types of data that can be collected using the suitable interface software.

5.2.1 *Real-time operational data*

Real-time operational data can be transmitted on demand through the communication lines and are not stored by the inverter. The AURORA Communicator software is available on the installation CD and may be used to transmit data to a PC (check for the latest version on www.power-one.com).

The following data is available:

- Grid voltage
- Grid current
- Grid frequency
- Power transferred to the grid
- Wind generator voltage
- Wind generator current
- Heatsink temperature)
- Serial Number and Part Number
- Manufacturing week
- Firmware revision code
- Daily energy output
- Leakage current of the system
- Total energy
- Partial energy
- Mean grid voltage
- Insulation resistance
- Leakage current to ground
- Date and time

5.2.2 Internally logged data

The AURORA inverters store the following data internally:

- Lifetime counter of grid connection time
- Lifetime counter of energy transferred to the grid
- Energy transferred to the grid every 10 seconds for the last 8,640 of 10-second periods (that covers more than 2 days of logged data)
- Partial counter of grid connection time (counter start time can be reset using the AURORA Communicator software)
- Partial counter of energy (uses the same start time as the partial time counter)
- Last 100 fault conditions with error codes and time stamp
- Last 100 changes to grid connection parameters with parameter code and new value.

All data can be retrieved via the RS-485 interface. In addition, the first two types of data are displayed on the LCD screen.

5.3 LED indicators

There are three LEDs on the side of the LCD display as shown in Fig. 18: the first LED from the left (POWER) indicates proper operation of the inverter, the LED in the middle (FAULT) indicates a fault condition, and the LED on the right (GFI) indicates a ground fault.

1. The green “Power” LED indicates that AURORA is operating correctly.
This LED flashes upon start-up during the grid monitoring routine. If a correct grid voltage is detected and the input voltage is high enough to start up the inverter, the LED stays on constantly. Otherwise, the LED keeps flashing until the wind turbine speed and therefore the input voltage becomes high enough to start up the inverter. In this condition, the display will read “ Waiting for Wind....”
2. The yellow “FAULT” LED indicates that AURORA has detected a fault condition. A fault description appears on the display.
3. The red “GFI” (ground fault) LED indicates that inverter has detected a ground fault in the wind turbine/rectifier system (DC side). When this kind of fault is detected, the AURORA inverter immediately disconnects from the grid and the corresponding fault message appears on the display. The inverter remains in this condition until the operator presses the ESC button to re-start the grid connection sequence. If the inverter does not reconnect to the grid after pressing the ESC button, then call service to troubleshoot the system.

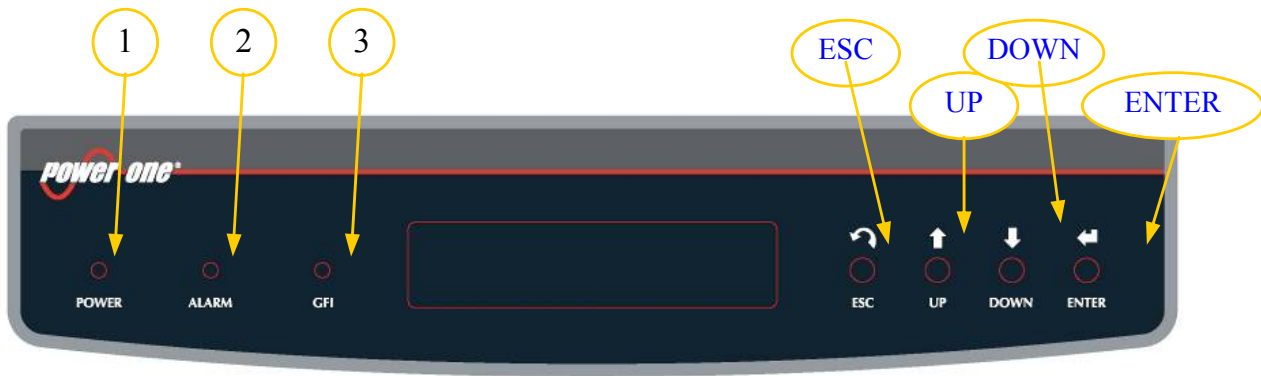



























Fig.18 - LED locations

Possible LED combinations and their meanings are listed below

KEY:

-  **LED on**
-  **LED blinking**
-  **LED off**
-  **Any one of the above conditions**

	LEDs Status	Operational Status	Remarks
1	green:  yellow:  red: 	Inverter is not operating	Input voltage less than 50Vdc at the input
2	green:  yellow:  red: 	Inverter is initializing, loading settings and performing grid check	It is a transition status while operating conditions are checked
3	green:  yellow:  red: 	Inverter is powering the grid	Normal operation
4	green:  yellow:  red: 	Inverter is shut down because of a GFI fault	Ground fault has been detected
5	green:  yellow:  red: 	Inverter detected a fault	The fault can be inside or outside the inverter. See the alarm code appearing on the LCD
6	green:  yellow:  red: 	Installation phase: inverter is disconnected from grid	During installation it refers to setup of the address for RS-485 communication
7	green:  yellow:  red: 	Inverter is disconnected from grid	Indicates a missing grid connection



NOTE: Inverter status is indicated by the corresponding LEDs and by a display message that provides a description of operation or fault condition (see next sections).

-
- G** **1) Standby mode**
Y AURORA is waiting for higher voltage on the input; this occurs
R when input voltage is too low to feed the inverter.
- G** **2) Initialization and grid check**
Y Initialization in progress: input power is sufficient to feed the
R inverter; AURORA is verifying start-up conditions (for instance:
input voltage value, insulation resistance value, etc.) and grid
monitoring routine has been launched.
- G** **3) AURORA is feeding the grid**
Y After completing a set of electronics and safety auto-test routines,
R the inverter starts the grid connection process.
During this stage AURORA automatically tracks and analyzes the
maximum power point (MPPT) of the wind generator.
- G** **4) Ground insulation fault**
Y AURORA indicates that insulation resistance was found to be too
R low.
This may be due to an insulation fault in the connection between
the wind generator inputs and the ground.



WARNING: Shock hazard! Do not attempt to correct this fault yourself. The instructions below have to be followed very carefully. Unless you are qualified to work on the equipment, contact a service professional.

What to do after an insulation fault has been found

When the red LED turns on, try to reset the fault indication by pressing the multi-function ESC button at the right side of the display. If the inverter reconnects to the grid, the fault was due to a one-time event. If this fault occurs frequently, have the system inspected by a service professional.

If the inverter does not reconnect to the grid, open both disconnect switches to place AURORA into a safe condition and contact an authorized service center to have the system repaired.

- G** **5) Malfunction/Fault indication**
Y Every time the inverter detects a malfunction or fault of the
R system, the yellow LED turns on and a message showing the type
of a problem found appears on the LCD.

-
- G** **6) RS-485 address setup indication**
Y During installation, the yellow LED will keep flashing until the address is acknowledged. For further information about entering the address, refer to section 6.3.
R
- G** **7) Grid disconnection**
Y If a grid failure event occurs while the system is operating, the yellow LED turns on continuously.
R

5.4 Messages and Error Codes

The system status is identified through message or error signals appearing on the LCD.

The tables below summarize the two types of signals that can be displayed.

MESSAGES identify current AURORA status; they do not relate to faults. The user is not required to take any actions; messages disappear as soon as the system is back to normal operating conditions. See W strings in the table below.

WARNINGS identify a possible fault of the equipment or of the connected parts. Alarm signals will disappear as soon as the causes are removed, except for ground insulation faults in the wind turbine/generator system, which have to be corrected by qualified personnel. Usually, when an error signal appears, an action is needed. This action will be managed as much as possible by the AURORA inverter itself or, in case this is not possible, the inverter will display all the necessary information to the person who will have to carry out the maintenance operations to fix the fault of the equipment or system. See E strings in the table below.

Message	Error code	Error type	Description
Sun Low	W001	//	Input Voltage under threshold <i>Input voltage under threshold (when off)</i>
Input OC	//	E001	Input Overcurrent
Input UV	W002	//	Input Undervoltage
Input OV	//	E002	Input Overvoltage
Int.Error	//	E003	No parameters
Bulk OV	//	E004	Bulk Overvoltage
Int.Error	//	E005	Communication Error
Out OC	//	E006	Output Overcurrent
Int. Error	//	E007	IGBT Sat
Sun Low	W011	//	Bulk Undervoltage
Int.Error	//	E009	Internal Error
Grid Fail	W003	//	Grid Fail <i>Wrong grid parameters</i>
Int.Error	//	E010	Bulk Low
Int.Error	//	E011	Ramp Fail
DC/DC Fail	//	E012	DcDc Error revealed by inverter
Wrong Mode	//	E013	Wrong Input setting (Single instead of dual)
Over Temp.	//	E014	Overtemperature
Cap. Fault	//	E015	Bulk Capacitor Fail
Inv. Fail	//	E016	Inverter fail revealed by DcDc
Int.Error	//	E017	Start Timeout
Ground F.	//	E018	I leak fail
Int.Error	//	E019	Ileak Sensor fail
Int.Error	//	E020	DcDc relay fail
Int.Error	//	E021	Inverter relay fail
Int.Error	//	E022	Autotest Timeout

Message	Error code	Error type	Description
Int.Error	//	E023	Dc-Injection Error
Grid OV	W004	//	Output Overvoltage
Grid UV	W005	//	Output Undervoltage
Grid OF	W006	//	Output Overfrequency
Grid UF	W007	//	Output Underfrequency
Z Grid HI	W008	//	Z grid out of range
Int.Error	//	E024	Unkown Error –
-----	//	E025	Riso Low (Log Only)
Int.Error	//	E026	Vref Error
Int.Error	//	E027	Vgrid Measures Fault
Int.Error	//	E028	Fgrid Measures Fault
Int.Error	//	E029	Zgrid Measures Fault
Int.Error	//	E030	Ileak Measures Fault
Int.Error	//	E031	Wrong V Measure
Int.Error	//	E032	Wrong I Measure
Fan Fail	W010	//	Fan Fail (No disconnection)
Int.Error	//	E033	UnderTemperature
	//	E034	Interlock Fail (Not Used)
	//	E035	Remote Off
	//	E036	Vout Avg <i>Average output voltage outside range</i>
	W012	//	Clock Battery Low (No disconnection)
	W013	//	Clock Failure (No disconnection)

5.5 Display LCD

5.5.1 Connection of system to the grid

The two-line Liquid Crystal Display is located on the front panel and shows:

- ✓ Inverter operating status and statistics;
- ✓ Service messages for operator;
- ✓ Error messages and fault indications.

During regular operation, the display will cycle through available data. The display changes to a different screen every 5 seconds or screens may be scrolled manually by pressing the UP and DOWN buttons located to the right of the display.

1) These two screens are displayed upon inverter start-up:

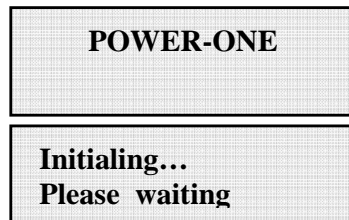

2) The following screens may appear while waiting for the connection to be established:



- While the system checks for grid connection to be established (“Missing Grid”), the yellow LED next to the display turns on continuously, while the green LED is flashing.
- When waiting for the input voltage to exceed 50Vdc (“Waiting Wind”), the green LED turns on steady.
- When the “Missing Grid” and “Waiting Wind” conditions are verified, the inverter is connected.

3) Time (seconds) to complete output voltage and frequency check.

It takes from 30 seconds to several minutes to complete the operation.



4) Shows instant output voltage value and within/outside range status.

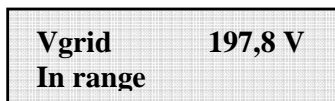

5) Shows instant output frequency value and within/outside range status.

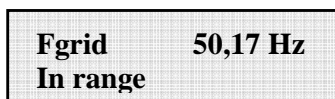

6) If measured instant values of voltage (step 4) and frequency (step 5) are outside of the allowed range, the following screens are shown alternately

- Next connections (screen 3)
- Vgrid (screen 4)
- Fgrid (screen 5)

7) Instant value of isolation resistance

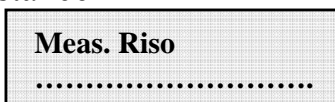

5.5.2 Error messages

After the connection is established, the inverter runs a test cycle. If wrong data are found, the cycle is interrupted and an error code is displayed. Error codes and their meaning are shown in the table in section 5.4

To modify the message shown in the display see the procedure in section 5.5.6.15 "Alarm Message".

Until the error is removed, the following screens are shown alternately:

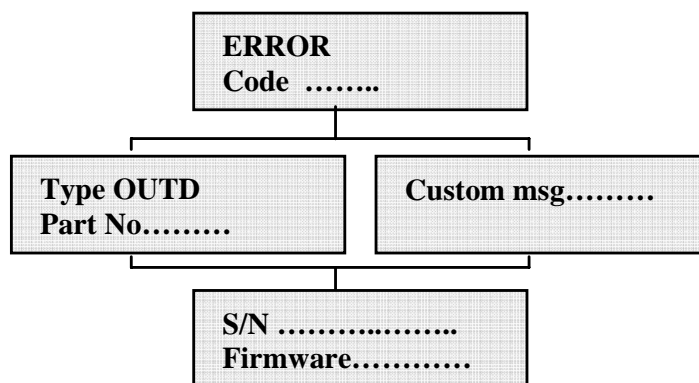

Once the error has been removed, the inverter resets all functions in progress and re-starts the connection (Sect.5.5.1 Connection of system to the grid, item 2)

- Missing Grid
- Waiting Wind

5.5.3 First phase - electric parameter monitoring

A FEW POINTERS ON DISPLAY KEY OPERATION:

During regular operation, the display will cycle through available data. The display shows a different screen every 5 seconds, screens may be scrolled manually by pressing the UP and DOWN buttons next to the display.

Pressing the ESC key (right next to the display) calls back the previous menu.



Auto-scroll is indicated by 2 arrows in the top left corner of the display (Fig.20).

To stop auto-scroll, press the ENTER button. A picture of the padlock will appear (Fig.21).

1A) If the parameters measured previously (see sect. 5.5.1) are correct, the system will proceed to the next checks. The 12 screens outlined below are shown alternately as mentioned in section “A FEW POINTERS ON DISPLAY KEY OPERATION”.

Type OUTD PN-----

2A) shows inverter serial number and firmware revision level.

S/N----- xxxxxx FW rel. C.0.1.1

3A)

E-tod	0	Wh
\$-tod	0.0	EUR

E-tod : Daily energy output.

\$-tod: Daily energy savings. Value is expressed in the set currency.

4A)

E-tot	-----
E-par	0 KWh

E-tot : Lifetime energy output (since first installation)
E-par : Partial energy output (during selected period)

5A)

P-out	0 W
T-inv	- °C

P-out : Measured instant output power
The second line of the display shows the higher of two temperatures:
T-inv: inverter heatsink temperature
T-boost: heatsink temperature

6A)

Ppk	W
Ppk Day	W

Ppk: Maximum peak power achieved since partial counter was activated
Ppk Day: Maximum peak power achieved during the day. Counter will reset when unit is powered off.

7A)

Vgrid	197
VVgrid Avg	0

Vgrid: Measured instant grid voltage
Vgrid Avg: Average grid voltage during the last 10 minutes of operation

8A)

Igrid	0.8 A
Fgrid	50.18 Hz

Igrid: Measured instant grid current
Fgrid: Measured instant grid frequency

9A)

V_{in}	0 V
I_{in}	0.0 A

V_{in}: input voltage value

I_{in}: Instant input current value

10A)

P_{in}	0 W
-----------------------	------------

P_{in}: Measured instant input power

11A)

R_{iso}	0.0 Mohm
I_{leak}	73 mA

R_{iso}: Measured insulation resistance. Unlike the parameters discussed above, this is not an instant value but a measurement taken one time during inverter start-up.

12A)

Inverter OK	
Wed 17 May 11 23	

If all items described above are tested OK, the inverter shows a corresponding message in the display top line along with date and time. Clock malfunctioning or other non function-related faults (meaning such faults that do not affect the inverter's ability to generate energy) are shown in the bottom line of the display in place of date and time.

The following error messages are provided:

- CLOCK FAIL indicates clock malfunction, contact service
- BATTERY LOW
- SET TIME, appears the first time the unit is powered up or after the battery has been replaced.
- FAN FAIL: contact service
- MEMORY FAIL: Data logging malfunction. Contact service.

5.5.4 Main menu

When the grid connection sequence described above and all electrical parameter checks are completed, other screens become available. These screens let you monitor inverter operation.

Pressing the ESC button gives access to 3 new screens:



- A FEW POINTERS ON DISPLAY KEY OPERATION:

- Press the UP and DOWN buttons to scroll through items.
- Press the ESC button to go back to the previous session (see sect. 5.5.3).
- Press ENTER (4th key from display) to open the selected submenu.

5.5.5 Statistics

Select the STATISTICS menu to display the following submenu:

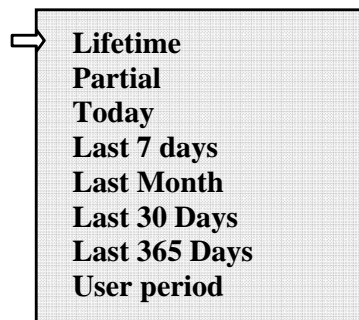

The display has 2 lines; use the keys at the side of the display to scroll through items or open the corresponding submenus as described in section 5.5.3 A FEW POINTERS ON DISPLAY KEY OPERATION.

An arrow on the left side of the display highlights your current selection as shown in the following figure:



5.5.5.1 Lifetime

Select Lifetime to view the following information:

Time	h
E-tot	KWh
Val.	EUR
CO2	Kg

Time: Lifetime operation time

E-tot : Lifetime energy output

Val. : Money earned

CO2: CO2 saving compared to fossil fuel

5.5.5.2 Partial

Select Partial to view the following information:

Time	h
E-par	KWh
Ppeak	W
Val.	EUR
CO2	Kg

Time: Total operation time since counter was last reset *

E-par: Total energy output since counter was last reset *

PPeak: Maximum peak power measured since Partial counter was activated

Val.: Money earned since counter was last reset *

CO2: CO2 saving compared to fossil fuels since counter was last reset *

- Hold the ENTER key (4th key from display) depressed for over 3 seconds to reset all counters in this submenu. After 3 seconds, a warning sound is repeated 3 times.

5.5.5.3 Today

Select Today to view the following information:

E-tod	KWh
Ppeak	W
Val.	EUR
CO2	Kg

E-tod: Total energy output during the day

Ppeak: Peak power achieved during the day

Val: Money earned during the day

CO2: CO2 saving compared to fossil fuels during the day

5.5.5.4 Last 7 days

Select Last 7 days to view the following information:

E-7d	KWh
Val.	EUR
CO2	Kg

E-7d: Total energy output during the last 7 days

Val. : Money earned during the last 7 days

CO2: CO2 saving compared to fossil fuels during the last 7 days

5.5.5.5 Last Month

Select Last Month to view the following information:

E-mon	KWh
Val.	EUR
CO2	Kg

E-mon: Total energy output during the month

Val. : Money earned during the month

CO2: CO2 saving compared to fossil fuels during the month.

5.5.5.6 Last 30 Days

Select Last 30 Days to view the following information:

E-30d	KWh
Val.	EUR
CO2	Kg

E-30d: Total energy output during the last 30 days

Val.: Money earned during the last 30 days

CO2: CO2 saving compared to fossil fuels during the last 30 days

5.5.5.7 Last 365 Days

Select Last 365 Days to view the following information:

E-365d	KWh
Val.	EUR
CO2	Kg

E-365d: Total energy output during the last 365 days

Val. : Money earned during the last 365 days

CO2: CO2 saving compared to fossil fuels during the last 365 days

5.5.5.8 User period

User period

This feature measures energy saving during a period selected by the user.

Press ENTER from the “User period” screen to access the following submenu:

Start	23 June
End	28 August

Use the display keys to set the start and end date of the period as follows:

- Use ENTER to move from one field to the next (from left to right)
- Use ESC to go back to the previous field (from right to left)
- Press ESC repeatedly to go back to the previous menus as described in sect. 5.5.3

To set days:

- Press DOWN to scroll numbers backwards (from 31 to 1)
- Press UP to scroll numbers from 1 to 31

To set the month:

- Press DOWN to scroll months from December to January
- Press UP to scroll months from January to December

If set dates are inconsistent, the display alerts the user to the problem:



5.5.6 Settings

Select SETTING from the Main menu (sect. 5.5.4) to display the first screen, which refers to the password:



Default password is 0000. It can be changed using the keys on display as usual:

- Use ENTER to move from one figure to the next (from left to right)
- Use ESC to go back to the previous figure (from right to left)
- Press ESC repeatedly to go back to the previous menus as described in sect. 5.5.3
- Press DOWN to scroll numbers backwards (from 9 to 0)
- Press UP to scroll numbers from 0 to 9

Type in the password and press ENTER to access information of this section:

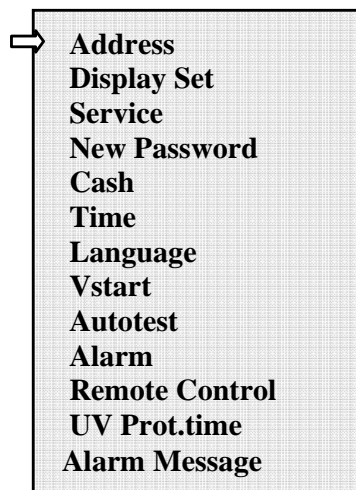

The display has 2 lines; use the buttons on the side of the display to scroll through items or open the corresponding submenus as described in section 5.5.4 **A FEW POINTERS ON DISPLAY DATA READING.**

An arrow on left side of the display highlights your current selection. When an item is selected, press ENTER to open the submenu.

5.5.6.1 Address

This function is used to set addresses for communication with inverters connected in the system on RS-485 line. You can assign numbers from 2 to 250. Press UP and DOWN to scroll through numbers.

If you do not want to manually set the address of each inverter, select the AUTO function and they will be assigned automatically.



5.5.6.2 Display set

This function is used to set display features:

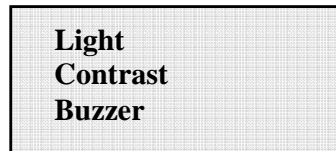

1) **Light**: display backlight setting:

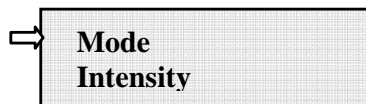

- Use the MODE submenu to set display backlight.

Select the Mode with the arrow, and press ENTER to open the relevant submenu. The following screen is:



ON: Light is always on

OFF: Light is always off

AUTO: Automatic light setting. It turns on every time a button is pressed and stays on for 30 seconds then gradually turns off.

2) **Contrast:** display light contrast

Available display light tones from 0 to 9.

Press UP and DOWN to scroll through numbers and press ENTER to select.

3) **Buzzer:** key tone setting

Selecting:

ON: key tone is on

OFF: key tone is off

5.5.6.3 Service

Only installers and their staff can gain access to this function, which is password-protected. The password can be provided by Power-One.

5.5.6.4 New password

This function is used to change the default password 0000.

To set your personal code, use the display keys as follows:

- Use ENTER to move from one digit to the next (from left to right)
- Use ESC to go back to the previous digit (from right to left)
- Press ESC repeatedly to go back to previous menus as described in 5.5.3
- Press DOWN to scroll numbers backwards (from 9 to 0)
- Press UP to scroll numbers from 0 to 9

5.5.6.5 Cash

This function helps quantifying energy savings.

Name	EUR
Val/KWh	00.50

Name: set desired currency, using keys as usual. Default currency is Euro.

Val/KWh: it indicates the cost of 1 KWh expressed in set currency. Default setting is 0.50 Euro.

5.5.6.6 Time

This function allows time and date setting.



Time 14:21
Date 17 May 2006

5.5.6.7 Language

It is possible to set the national language or English.



⇒ **English**
Italiano

5.5.6.8 START UP voltage

Start-up voltage can be set according to the characteristics of the wind turbine/generator system. Voltage range can be 50V to 350V. The default setting is 50V. This parameter can be changed by means of the display keys.

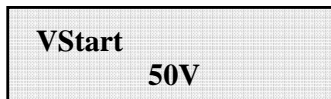

VStart
50V

5.5.6.9 Autotest

Self-test to verify correct operation of the protection and the grid interface device, as required by UL 1741 standard.



Autotest

Press ENTER to access all information of this section:

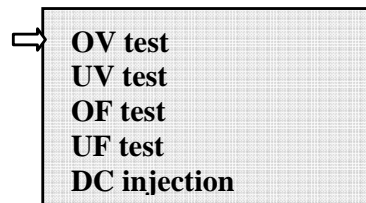

⇒ **OV test**
UV test
OF test
UF test
DC injection

OV = Max. voltage

UV = Min. voltage

OF = Max. Frequency

UF = Min. Frequency

DC injection = DC component of the output current. This component shall not exceed >0.5% of the inverter maximum rated current or the unit will switch off.

The display has 2 lines; use the buttons on the side of the display to scroll through items or open the corresponding submenus.

An arrow on the left side of the display highlights your current selection. When an item is selected, press ENTER to open the submenu.

As soon as a test is selected, the display shows

Test in process

During the test the display gives test progress indication.

If the test is passed, depending on selected item, the display shows:

Test V= V OK T=ms	Test F=.... Hz OK T=ms	Test I=.... mA OK T=ms
--	--	--

V= measured voltage; T= time necessary to take the measurement

F= measured frequency; T= time necessary to take the measurement

If the test has failed, the following will be displayed:

Test V= V Fail T=ms	Test F=.... Hz Fail T=ms	Test I=.... mA Fail T=ms
--	--	--

V= measured voltage; T= time necessary to take the measurement

F= measured frequency; T= time necessary to take the measurement

5.5.6.10 Alarm

The inverter features an alarm function that controls a relay which contacts are connected to the terminal block accessible through the front panel as shown in Fig. 22. The NC and NO contacts can be used to activate external circuitry or a visual or audio alarm in case the inverter is disconnected from the grid (no energy output) or for any alarm event generated by the system.



Fig. 22 - Alarm contacts terminal block

This function can activate two alarm modes. Press ENTER to open the relevant submenu:

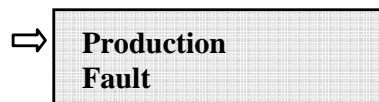

An arrow on the left side of the display highlights your current selection. When an item is selected, press ENTER to confirm activation of chosen mode.

PRODUCTION: Relay is only activated when the inverter is connected to the grid (contact closing across terminals “N.O.” and “C”)

FAULT: triggers relay activation (contact closing across terminals “N.O.” and “C”), only when an error signal occurs, i.e. when grid is disconnected, excluding Input Undervoltage.

5.5.6.11 Remote control

This function is used to disable the inverter’s manual shutdown. Operation is as follows:

- set to ENABLE to activate manual ON/OFF function
- set to DISABLE to disable manual ON/OFF function, so that the inverter will be automatically controlled only by the input voltage.

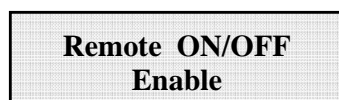

Manual ON and OFF input is read on inverter digital input. When set to OFF, the display will cycle through the following screens:

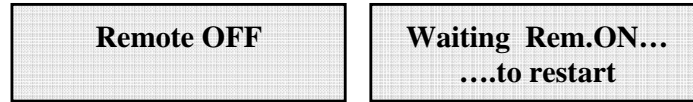

5.5.6.12 UV Prot.time

This function is used to set the inverter connection time after the input voltage drops below the undervoltage protection threshold that is set at 40V.

For example: if UV Prot.time is set at 60 seconds, and Vin voltage drops below 40V at 9:00am the inverter will stay connected to the grid (at 0 power) until 9:01am.

Power-One sets this time at 60 seconds. The user can change this setting and set it from 1 second to 3,600 seconds.

5.5.6.13 Alarm Message

It is possible to program the error message to be shown in the display using the following procedure:



Press to access the following submenu:

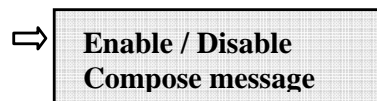

Use the button on the left side of the display to move UP (switch 2) and DOWN (switch 3) the arrow and press ENTER (switch 4) to select the desired function.

Once the menu ENABLE/DISABLE is selected the following screen will appear. It is possible to enable or disable the custom error message function in this screen:

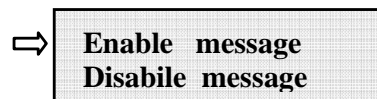

Select the line ENABLE MESSAGE and press ENTER, the following screen will appear on the display:

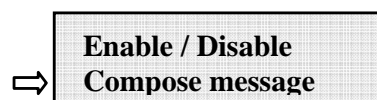

Select COMPOSE MESSAGE. It is now possible to write the first line of the message.

Message row 1:

The maximum number of characters is 16. Pressing Enter 17 times will allow entering the second line of the error message

Message row 2:

To write the message the same switches are used according to the following procedure:

- ENTER (switch 4) allow to move from one position to the other (from the left to the right)
- ESC (switch 1) allow to go back to the previous position other (from the right to the left)
- pressing ESC several time is possible to go back to the previous menu as described on 5.5.3
- UP (switch 2) allow selecting the letter or number for each position (from low to high)
- DOWN (switch 3) allows selecting the letter or number for each position (from high to low).

5.5.7 Info

This menu is used to display all AURORA data:

- Part No. (part number)
- Serial No. – Wk – Yr (serial number, week, year)
- Fw rel (firmware release level)

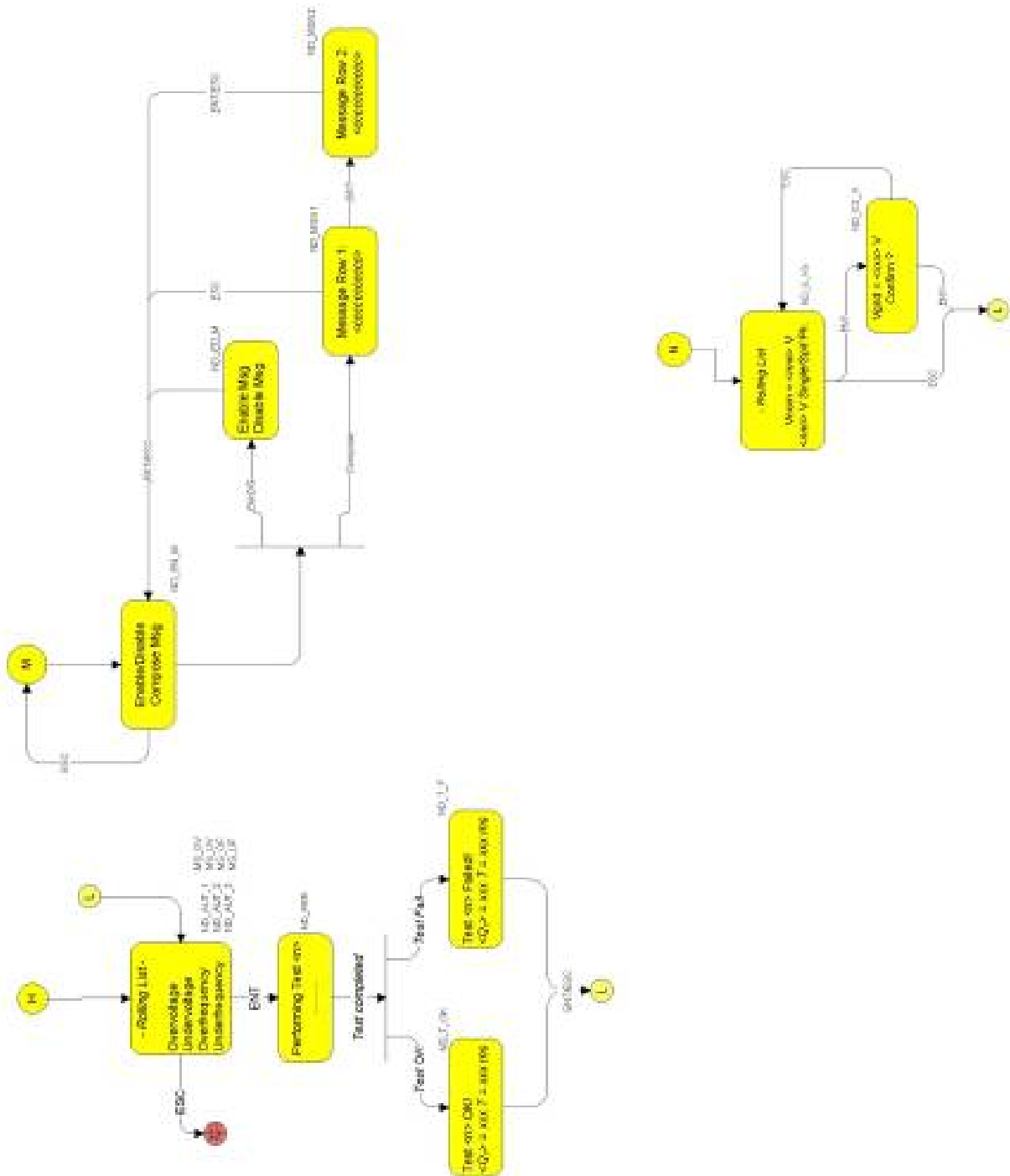

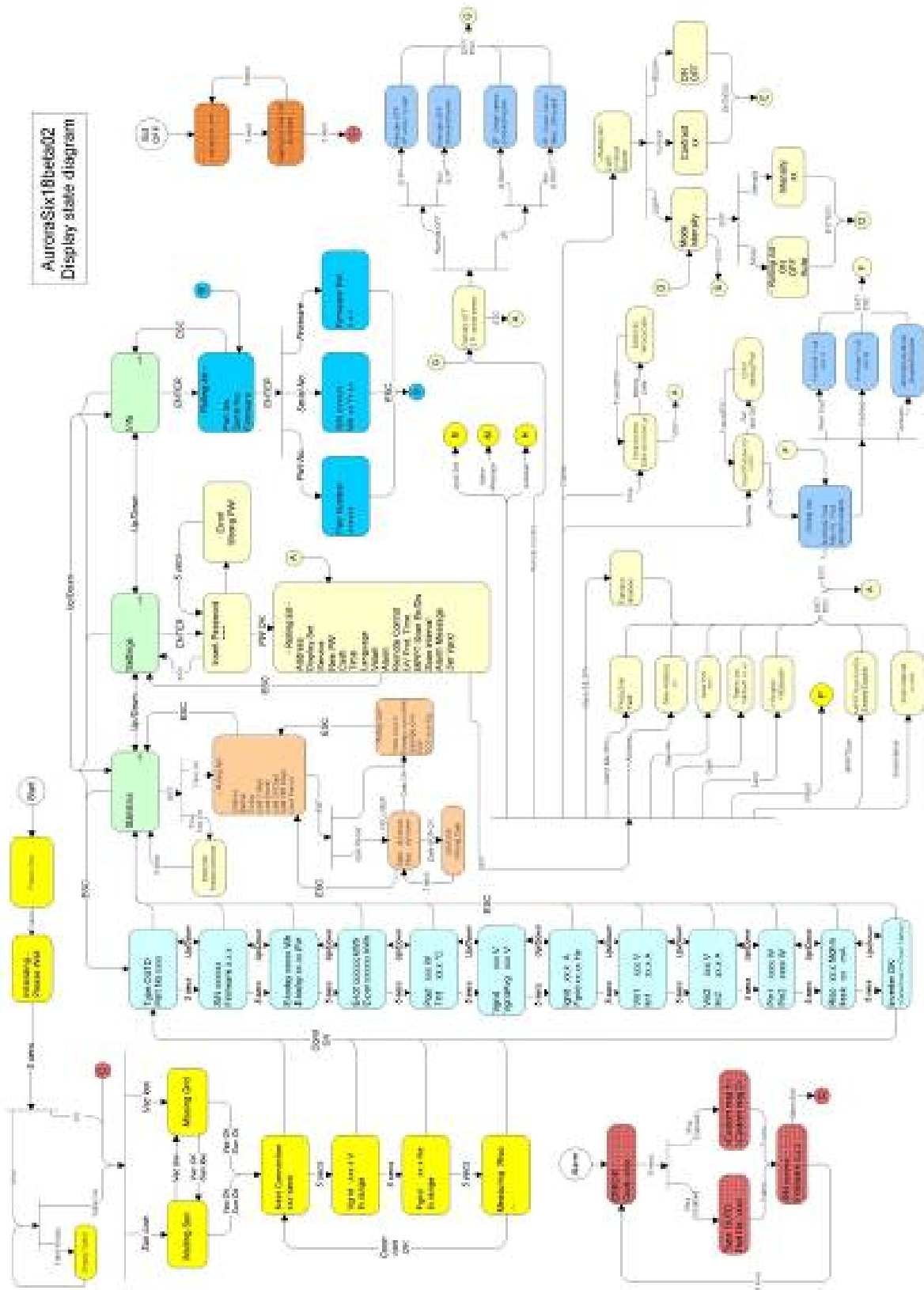

6 DATA MONITORING AND COMMUNICATION

6.1 Connection through RS-485 serial port or RJ12 connector

6.1.1 RS-485 serial port

The RS-485 serial port uses a three-wire cable: two wires are for signals and the third one is for ground connection. Cable is routed through the holes located at the bottom of the inverter. The holes are sealed with waterproof plugs (see Fig. 23).

Supplied cable glands must be installed in the suitable hole.



Fig.23 - Holes for cables necessary for RS-485 port connection or wiring for RJ12 connectors connection.

For easier installation, the inverter features two holes so that the input and output cables can be separated in case more units are connected in a daisy chain.

After passing through the cable gland, cables are connected inside the unit to the RS-485 terminal blocks that can be reached by removing the front panel. Refer to p. 3.7 for details on front cover removal and installation.

- Signal wires must be connected to the +T/R and –T/R terminals
- Ground wire must be connected to the RTN terminal

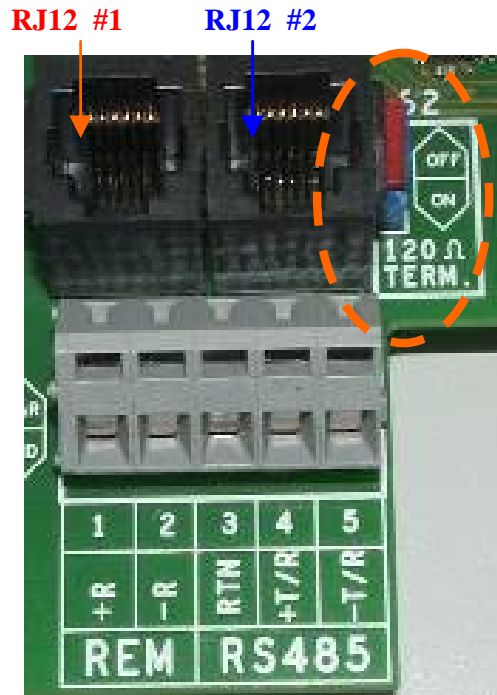

Fig.24 - Terminals for connection to RS-485 serial line and S2

6.1.2 RJ12 connectors

As an alternative to the RS-485 serial connection, either for a single unit or for multiple units connected in daisy chain, the inverter connection can be performed by using RJ12 connectors (see Fig. 24).

Wiring is again routed through the holes located at bottom of the inverter. Input wiring passes through one hole and is to be assembled to one of the RJ12 connectors (does not matter whether it is #1 or #2 since signals are connected in parallel).

Output wiring goes out from the other RJ12 connector through the other hole and reaches the next unit.

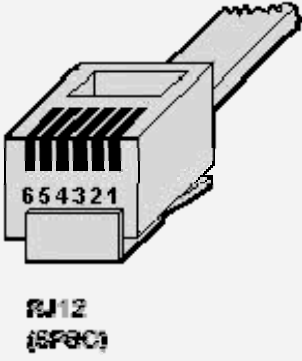
RJ12 connectors			
	Pin #	Signal Name	Description
	1		Not Used
	2	+TR	+ Data Line Required for RS485 communication.
	3	+R	Remote OFF Required or Remote OFF control (see chapter 5.5.6.11 for details).
	4	-TR	- Data Line Required for RS485 communication.
	5		Not Used
	6	RTN	Signal Return Common reference for logical signals.

6.1.3 Daisy chain

RS-485 terminal block or RJ12 connectors can be used to connect a single AURORA inverter or many AURORA inverters connected in a daisy chain. Maximum number of inverters that can be connected in a daisy chain is 248. Recommended maximum length of this chain is 4,000 feet.

In case many inverters are connected in a daisy chain, it is necessary to assign an address to each unit. Refer to paragraph 5.5.6.1 for instructions on how to set addresses.

The last inverter of the chain must have line termination contact active (S2 switch -120Ω TERM set to ON). See Fig. 24.

Any AURORA inverter is supplied with the default address two (2) and with the S2 switch in the OFF position.

In order to ensure optimum communication on the RS-485 line, Power-One recommends connecting a PVI-RS232485 adapter between the first unit of the daisy chain and the computer. See Fig. 25 for further details.

Other RS-232 to RS-485 converters available on the market can also be used but Power-One does not guarantee correct operation since equipment has never been tested with those devices. Moreover, some of those converters require external termination impedance, which is not necessary for the PVI-RS232485.

The following diagram shows how to connect multiple units in a daisy chain configuration.

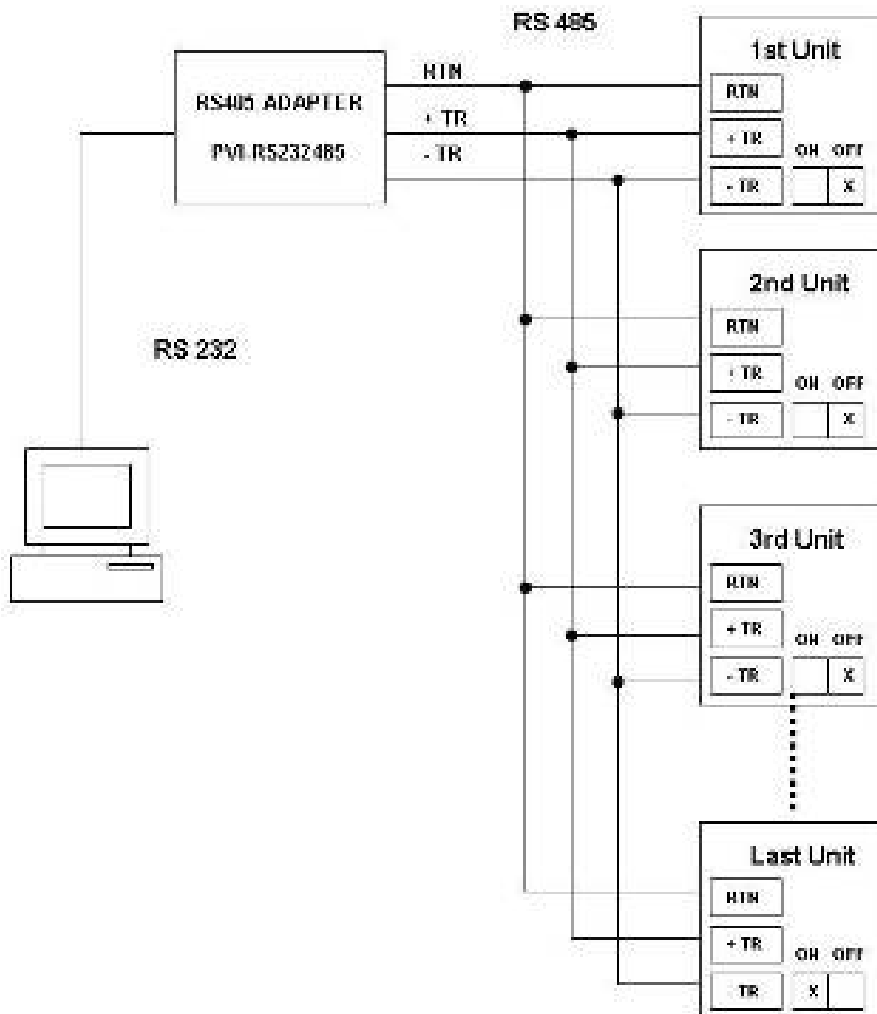

Fig. 25 - Daisy chain connection of multiple inverters



NOTE: When using a RS-485 link there can be up to 248 inverters connected on the same link. Choose any address between 2 and 248



NOTE: When using a RS-485 link, in case one or more inverters are added later to the system, always remember to switch back to the OFF position the switch S2 of the former last inverter of the system.

6.2 Serial connection with USB port

Serial connection through a USB port allows connection of a single inverter to a personal computer equipped with a USB 2.0 interface and dedicated software supplied by Power-One. PC-inverter connection cable is a standard USB 2.0 cable, 16 feet long, with terminals of the A and B type. Just remove the waterproof plug located on AURORA side to make the connection (see Fig. 26).



Fig.26 - USB connection opening

6.3 Measurement Accuracy

The following table shows measurement accuracy for each value monitored and reported by the AURORA inverter:

	Name	Unit	Resolution		Accuracy
			Display	Value	
Input voltage PV N°1	VP1	Vdc	1V	600mV	2%
Input voltage PV N°2	VP2	Vdc	1V	600mV	2%
Input current PV N°1	IP1	Adc	0.1A	25mA	2%
Input current PV N°2	IP2	Adc	0.1A	25mA	2%
Output power PV N°1	Pin1	W	1 W	10 W	2%
Output power PV N°2	Pin2	W	1 W	10 W	2%
Output voltage	Vout	V	1V	-	2%
Output current	Iout	A	0.1A	-	2%
Output power	Pout	W	1 W	-	2%
Frequency	Freq	Hz	0.01	0.01	0.1%
Accumulated energy	Energy	Wh	1Wh		4%
Time counter	Lifetime	hh:mm:ss	1s		0.2
Partial time counter	Partial Time	hh:mm:ss	1s		0.2

7 TROUBLESHOOTING

AURORA inverters comply with standards set for grid-tied operation, safety and electromagnetic compatibility.

Before being delivered, the product has been successfully subjected to several tests to check operation, protections, performance and durability.

All these tests, together with the system ensuring Power-One quality, guarantee optimal operation of the AURORA inverters.

In case of a possible malfunction of the inverter, follow the steps below:

- ✓ Work under safe conditions, as stated in p.3.5 and throughout this manual.
- ✓ Check that connections between the AURORA inverter, wind generator and power distribution grid have been made correctly.
- ✓ Carefully observe which LED is blinking and read the signals appearing on the display; then, following the instructions given in p.5.3, 5.4 and 5.5, try to identify the type of fault found.

If the malfunction cannot be removed by following those instructions, contact the service center or the installer.

Before contacting the service center, keep the following information handy:

INFO AURORA



NOTE: Information to be found directly on LCD

- ✓ AURORA model?
 - ✓ Serial number?
 - ✓ Week of production?
 - ✓ LED flashing?
 - ✓ Light blinking or steady?
 - ✓ Signal displayed?
-
- ✓ Malfunction short description?
 - ✓ Can malfunction be reproduced?
 - ✓ If so, how?
 - ✓ Does malfunction appear periodically?
 - ✓ If so, how frequently?
 - ✓ Is malfunction present from installation?
 - ✓ If so, has it worsened?
 - ✓ Description of the atmospheric conditions when the malfunction appeared.

INFO on the wind generator

- ✓ Make and model of the wind turbine and generator.

8 TECHNICAL FEATURES

8.1 Input Values



WARNING: The output voltage from the rectifier shall always be less than 600VDC.



WARNING: Inverter is provided with a linear output power derating depending on the input voltage, starting from 530 Vdc (100% output power) to 580 Vdc (0% output power)

Description	Value PVI – 6000-OUTD-UK-W
Max. absolute input voltage	600 Vdc
Input voltage, MPPT operating range	from 50 Vdc to 580 Vdc
Input voltage, MPPT operating range at full power	from 180 Vdc to 530 Vdc
Max. short circuit current.	44 Adc
Max. operating input current	36 Adc
Max. input power	8,000 W
Generator Ground fault protection	Ground fault detector provided

8.2 Output Value

Description	Value PVI – 6000 – OUTD – UK -W
Nominal output power	6,000 W
Grid voltage, maximum range	180 to 264 Vac
Grid voltage, nominal	230 Vac
Grid voltage, operating range	82% to 115% of nominal voltage (188.6 to 264Vac for V=230Vac)
Grid frequency, maximum range	47 to 63 Hz
Grid frequency, nominal	50 Hz
Grid frequency, operating range	49.72 to 50.28 Hz
Nominal output current	26 Arms
Max. output current	30 Arms
Output over current protection	40 Arms

8.3 Grid protection characteristics

Anti islanding protection	Complies with G83/1 standard.
---------------------------	-------------------------------

8.4 General characteristics

Description	Value PVI – 6000 – OUTD-UK-W
Maximum efficiency	97% (>96 Euro)
Internal consumption during standby	< 8 W
Internal consumption during nighttime	< 1 W
Operating ambient temperature	-25°C to +60°C (*)
Casing protection rating	IP65 / Nema 4X
Audible noise with internal fan on	< 50 dbA @ 1m
Size (height x width x depth):	29.1” x 12.8” x 7.5”
Weight	59.5 lbs
Relative Humidity	0 – 100 % condensation point

(*) Full power guaranteed up to $T_{amb} = 40^{\circ}\text{C}$ (as long as unit is not exposed to direct sun radiation)

8.5 Power Derating

In order to ensure reliable operation under different ambient and loading conditions, the AURORA inverters automatically decrease the output power as a function of the temperature and input voltage.

Power reduction due to environmental conditions

Power reduction and temperature at which it occurs depend on many parameters other than ambient temperature, such as input voltage, grid voltage, etc. The AURORA inverters can thus decrease power output during certain periods of the day according to these parameters.

In any case, the AURORA inverters deliver full output power up to 40°C ambient as long as they are not directly exposed to sunlight or other heat sources.

Power reduction due to input voltage

The graph in Fig 27 shows automatic power output derating as a function of the input voltage.

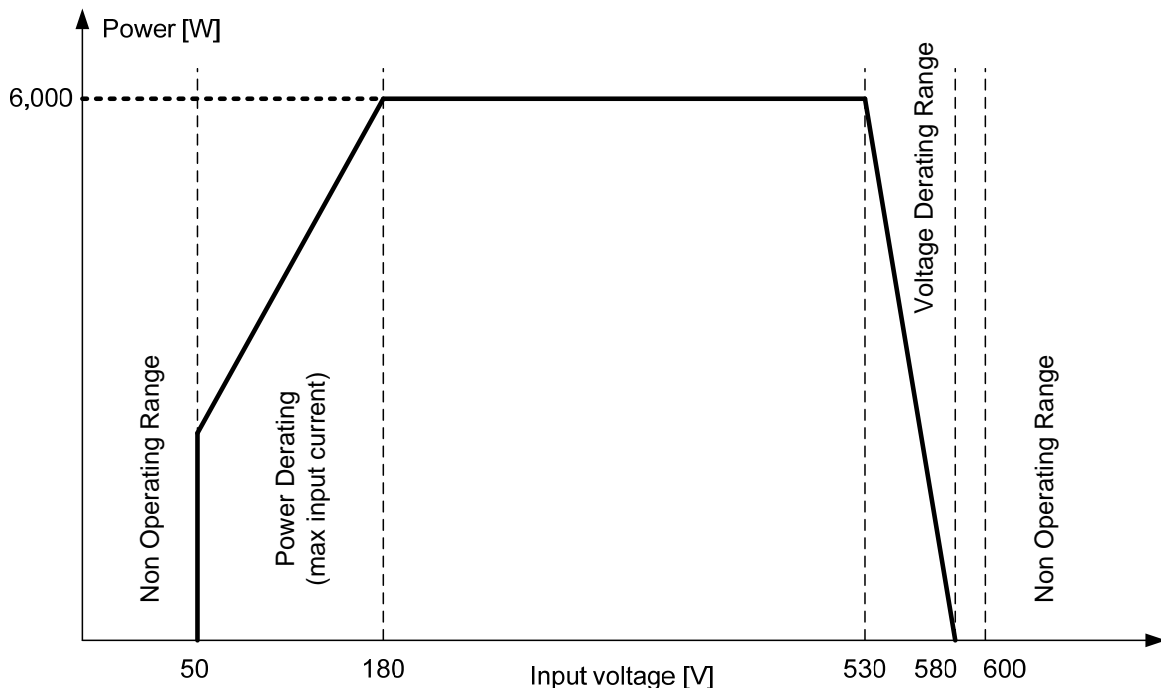

Fig. 27 - Output power derating due to the input voltage

Power derating due to environmental conditions and to the input voltage can occur at the same time. In this case the available output power is determined as a lower of the two numbers.



Certificate G83/1

The results of the G83/1 tests are summarized in this certificate.

Power-One Italy S.p.a. declares that the units shipped to the UK are characterized by the following features:

- The internal specification and parameters are set to be compliant with G83/1 engineering requirements
- All units have identical internal parameter setting.
- These parameters cannot be changes by a user, an installer or by any person other than the manufacturer.
- All units are tested before shipping according to G83/1 engineering specification.

SSEG DETAILS

SSEG Type Reference:	WIND TURBINE GRID TIED INVERTER
SSEG Model Reference:	PVI-6000-OUTD-UK-W, PVI-5000-OUTD-UK-W
SSEG Technology (as per Annex):	ANNEX C. PHOTOVOLTAIC (PV)
Manufacturer:	Power-one Italy S.p.A.
Telephone number:	+39-055-91951
Fax number:	+39-055-9195248
Address	Via S. Giorgio, 642 52028 Terranuova Bracciolini Arezzo - Italy
Maximum export capability (SSEG rating less parasitic load)	6000W (PVI-6000-OUTD-UK-W) 5000W (PVI-5000-OUTD-UK-W)
Nominal Output AC Power	6000W (PVI-6000-OUTD-UK-W) 5000W (PVI-5000-OUTD-UK-W)

TEST HOUSE DETAILS

Name:	Power-one Italy S.p.A. - R.& D. Department
Address:	Via S. Giorgio 642, 52028 Terranuova Bracciolini, Arezzo - Italy
Telephone number:	+39-055-91951
Fax number:	+39-055-9195248
E-mail address	service@power-one.com

TEST RESULTS SUMMARY

Power Quality:

- Harmonic Current Emission as per BS EN 61000-3-2, Class A
- Voltage Fluctuation and Flickers as per BS 61000-3-3
- DC Injection
- Power Factor

Under/Over Frequency Tests

Under/Over Voltage Tests

Reconnection Times

Loss of Mains Test

Power-One Italy S.p.a.
Terranuova Bracciolini, 28 May 2008

Giuseppe Ricci
(Site Director)

Rev. 28/05/2008	www.power-one.com	Page 1 of 2
File: PVI-6000(5000)-OUTD-UK-W_CertificateG83-1.doc		



G83/1 TEST RESULTS DETAILS – TYPE VERIFICATION TEST SHEET

POWER QUALITY

Harmonic Current Emission as per BS EN 61000-3-2 (Class A)								
Harmonic	2 nd	3 rd	5 th	7 th	9 th	11 th	13 th	15 th ..39 th
Limit [A]	1.08	2.3	1.14	0.77	0.4	0.33	0.21	0.15 x (15/n)
Test Value [A]	0.048	0.11	0.07	0.28	0.14	0.14	0.09	<0.09

Voltage Fluctuation and Flicker as per BS EN 61000-3-3				
	Starting	Stopping	Running	
Limit	4%	4%	$P_{st}=1.0$	$P_{it}=0.65$
Test Value	0.159	0.235	0.038	0.029

DC injection			Power Factor			
G83/1 Limit	20mA, tested at three power levels			0.95 lag – 0.95 lead at three voltage levels		
Test Level	10%	55%	100%	212 Vac	230Vac	248Vac
Test Value	-1mA	+10mA	+13mA	0.99	0.99	0.99

UNDER/OVER FREQUENCY TESTS

Parameter	Under Frequency		Over Frequency	
	Frequency	Time	Frequency	Time
G83/1 Limit	47 Hz	0.5 (5.0) sec	50.5 Hz	0.5 (5.0) sec
Actual setting	47.02 Hz	0.320 sec	50.48 Hz	0.320 sec
Trip value	47.01 Hz	<0.4 sec	50.49 Hz	<0.4 sec

UNDER/OVER VOLTAGE TESTS

Parameter	Under Voltage		Over Voltage	
	Voltage	Time	Voltage	Time
G83/1 Limit	207 V	1.5 (5.0) sec	264 V	1.5 (5.0) sec
Actual setting	211.59 V	1.3 sec	259.2 V	1.3 sec
Trip value	>212 V	<1.360 sec	<260 V	<1.360 sec

RECONNECTION TIMES

	Under/Over voltage	Under/Over Frequency	Loss of Main
Minimum Value	180 sec	180 sec	180 sec
Actual setting	180 sec	180 sec	180 sec
Recorded value	>182 sec	>182 sec	>182sec

LOSS OF MAIN TESTS

Method used	Active Power Variation and Rate Of Change Of Frequency		
	10%P _{rated}	55%P _{rated}	100%P _{rated}
G83/1 Limit	0.5 (5.0) sec	0.5 (5.0) sec	0.5 (5.0) sec
Trip setting	-	-	-
Trip value	<3.0 sec	<3.0 sec	<3.0 sec

SSEG Short Circuit Current Contribution Test

According to Clause C.4.6, as Photovoltaic SSEGs are inverter connected, they are deemed to automatically comply with regulations and no further tests are required.

SELF MONITORING – SOLID STATE SWITCHING

Not applicable because electro-mechanical relays are used

– End of document –